

# Solshield High Performance Damp Proof Membrane

## Description:

Solshield High Performance DPM is a multi-layer low density reinforced polyethylene membrane, reinforced with a polypropylene reinforcing grid.

- BBA Cert 20/5737.
- Compliant to NHBC Standards 2019, Chapter 5.1.
- CE Marking Standard EN13967:2012.
- High strength and resistance to puncture.
- Suitable for use with the Solco DPC System Accessories.

This membrane is particularly suited for applications where heavy duty foundations and steel reinforced slabs are to be installed, and where a durable, robust and high puncture-resistant membrane is better suited.

Solshield High Performance DPM is fully compliant with the standards for damp proof membranes as required by the UK building regulations. Solshield HP DPM provides a barrier for moisture, usually used within building foundations. It can also be used for a range of other damp proofing applications. Solshield HP DPM is suitable for use in concrete floors in domestic and commercial (schools, hospitals leisure, shopping centres, etc.) applications, in accordance with Clause 11 of CP 102:1973, where there may be capillary rise of moisture but not where it may be subject to hydrostatic pressure.

Solshield HP DPM should be jointed using welding for the most demanding installations or jointed using the range of Solco Tapes and ancillary items for all other instances (as shown below).

Solco can also produce DPM in a range of sizes and specifications to meet your specific needs.

## General:

Solshield HP DPM should not be installed at temperatures below 5°C, to prevent the risk of surface condensation. The membrane must be installed and fixed in accordance with the relevant clauses in BRE Report BR 211:2015.

The membrane should be installed on a sand blinding layer, Solshield P30 protection fleece, or a smooth concrete float finish. In order to provide a continuous barrier across the cavity, Solshield HP DPM should be taken through the blockwork and incorporated below the damp proof course cavity tray in the outer leaf.

SOLSHIELD HP DPM is suitable for installation with block & beam floor application with 150mm clear void, reinforced raft foundation and in situ suspended slab.

Long periods of exposure to ultraviolet light will reduce the effectiveness of the membrane.

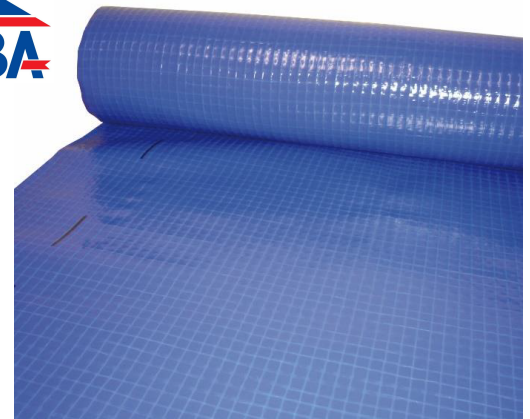

## Technical Data:

Property	Test Method	Value
Thickness	EN 1849-2	0.50mm
Thickness - Between Scrim	Micrometer	0.30mm
Width	EN 1849-2	2.0m
Length	EN 1849-2	50m
Weight	EN 1849-2	370g/m <sup>2</sup>
<b>Hydraulic Properties</b>		
Water Column Test	EN 20811	Pass
Resistance to Water Penetration	EN 13967, EN 1928	Pass
Durability of Watertightness against Ageing	EN 1296, EN 13967, EN 1928	Pass
<b>Mechanical Properties</b>		
Resistance to Static Load	EN 12730 B	20kg
Tensile Strength (MD)	EN 12311 - 1	500N/mm
Tensile Strength (CMD)	EN 12311 - 1	470N/mm
Tensile Elongation (MD)	EN 12310 - 1	15%
Tensile Elongation (CMD)	EN 12310 - 1	20%
Puncture Resistance (CBR)	EN 12236	1.04kN
Resistance to Tearing (Nail Shank) (MD)	EN 12310 - 1	400N
Resistance to Tearing (Nail Shank) (CMD)	EN 12310 - 1	350N
<b>Durability and Chemical Resistance</b>		
Radon Permeability	K124/02/95	4.3x10 <sup>-12</sup> m <sup>2</sup> /s
Carbon Dioxide Permeability	BS EN ISO 15015 - 1	<514 ml/m <sup>2</sup> /day/atm
Methane Permeability	BS EN ISO 15015 - 1	<514 ml/m <sup>2</sup> /day/atm

## Storage and Handling on Site:

SOLSHIELD HP DPM is classified as non-hazardous (code of practice CP102 1973).

Rolls should be stored on a flat surface, kept under cover, and protected from sunlight and mechanical damage.

The product is chemically inert and any acids or alkalis present in the subsoil will not affect the membrane.

Do not use when exposed to sunlight and general outdoor weather conditions for long periods of time.

Quality control during the laying of the membrane is extremely important. The membrane should be protected either through the use of temporary protection over its whole area or the immediate laying of the concrete slab.

Care should be taken when handling building materials over the exposed surface.

Solco, Unit 51, Portmanmoor Road Industrial Estate, Ocean Park, Cardiff, CF24 5HB

## Installation:

1. The membrane must only be applied to surfaces that have a smooth finish - free from voids, projections, and mortar deposits. Surfaces should be dry and free from dust and frost. In order to provide a continuous barrier across the cavity, Solshield HP DPM should be taken through the blockwork and incorporated below the damp proof course cavity tray in the outer leaf.
2. Concrete surfaces should be dense. Vertical surfaces of brickwork and blockwork must be dry and rendered to provide an even surface. Brickwork or blockwork not rendered must be flush pointed to give a smooth surface without sudden changes in level.
3. Solshield HP DPM is rolled out with the coloured side up, ensuring that it is properly aligned. All end and side overlaps should be a minimum of 100mm and prepared.
4. When the membrane is laid below the concrete slab, it should be loose-laid to accommodate any small movements.
5. All surfaces must be dried thoroughly prior to joining. Roll edges can be welded or taped.
6. The continuity of the damp proofing must extend over the footprint of the building, and the membrane must be sealed to a damp-proof course where required.
7. The membrane should be covered by a screed or other protective layer, such as Solco Protection Fleece, as soon as possible after installation. If blockwork protection is used, care must be taken to avoid damage to the membrane during construction. Care should be taken when handling building materials over the exposed surface.

## Jointing Detail:

1. Apply Solco Double Sided Butyl Tape around 50mm from the membrane edge, leaving the backing paper on.
2. Lay the next membrane, overlapping the first by a minimum of 100mm.
3. Remove the backing paper from the double sided butyl tape and join the top sheet to the bottom sheet, by applying pressure with a hand roller.
4. Where the membranes overlap, apply Solco Single Sided Foil Tape, equidistant on both membranes (see detail). All service entry points must have airtight seals. Top hats and corner pre-forms must be sealed using double sided butyl tape.

### Typical Jointing Details for Solshield HP DPM

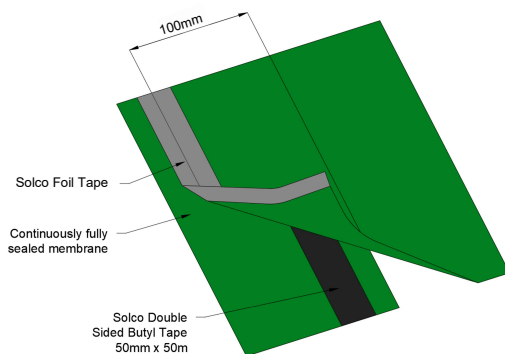

Typical Lap Detail

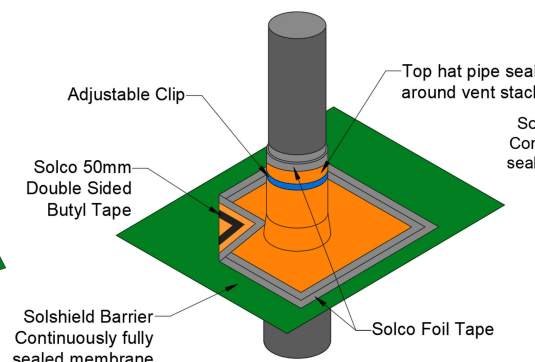

Typical Penetration Detail

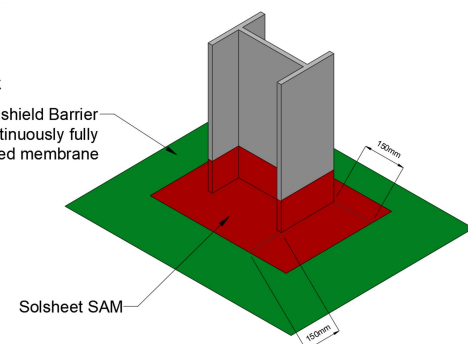

Typical Column Detail

**Note:**

All service entry points must have airtight seals. Top hats and corner pre-forms must be sealed using double sided butyl tape.

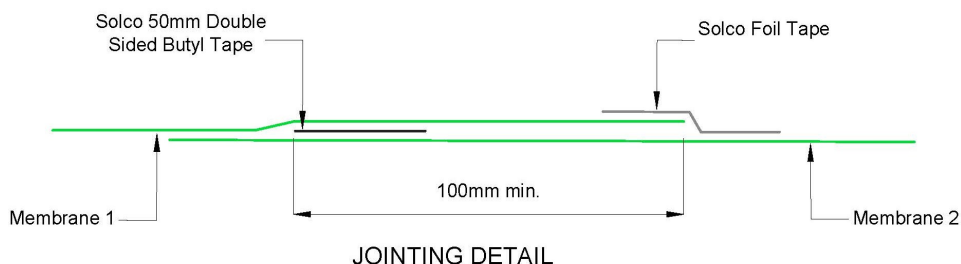

### Ancillary Products

Solco Foil Backed Jointing Tape	Single Sided Tape	75mm x 50mm	Securing laps & joints	Rolls
Solco Double Sided Butyl Tape	Butyl Adhesive Tape	50mm x 10m	Securing joints and laps	Rolls
Solco Top Hats	Polymeric	Various	For sealing around penetrations through gas membrane	Each
Solcourse HP DPC	A flexible bitumen free polymeric damp proof course	300mm - 1000mm	DPC	20m Rolls
Solco Int / Ext Corner Cloaks	Prefabricated corner details			
Solco P30 Protection Fleece	To form a protective layer to prevent damage to the membrane	2m x 50m	Protection Fleece	Rolls
Solco HP Emulsion / Primer	Used to provide adhesion to bitumen enhanced geomembranes	5L & 25L	Primer	Drums
Solseal Flexible Liquid Membrane	A flexible and elastomeric membrane	5L & 25L	Liquid Membrane	Drums

Solco, Unit 51, Portmanmoor Road Industrial Estate, Ocean Park, Cardiff, CF24 5HB